

SLIDE POTENTIOMETER

Rail Master Type



◆ FEATURE

- Excellent operation feeling and high-precision characteristics.
- Low residual resistance and long life.

◆ APPLICATIONS

- Fader control in mixer and high grade audio.

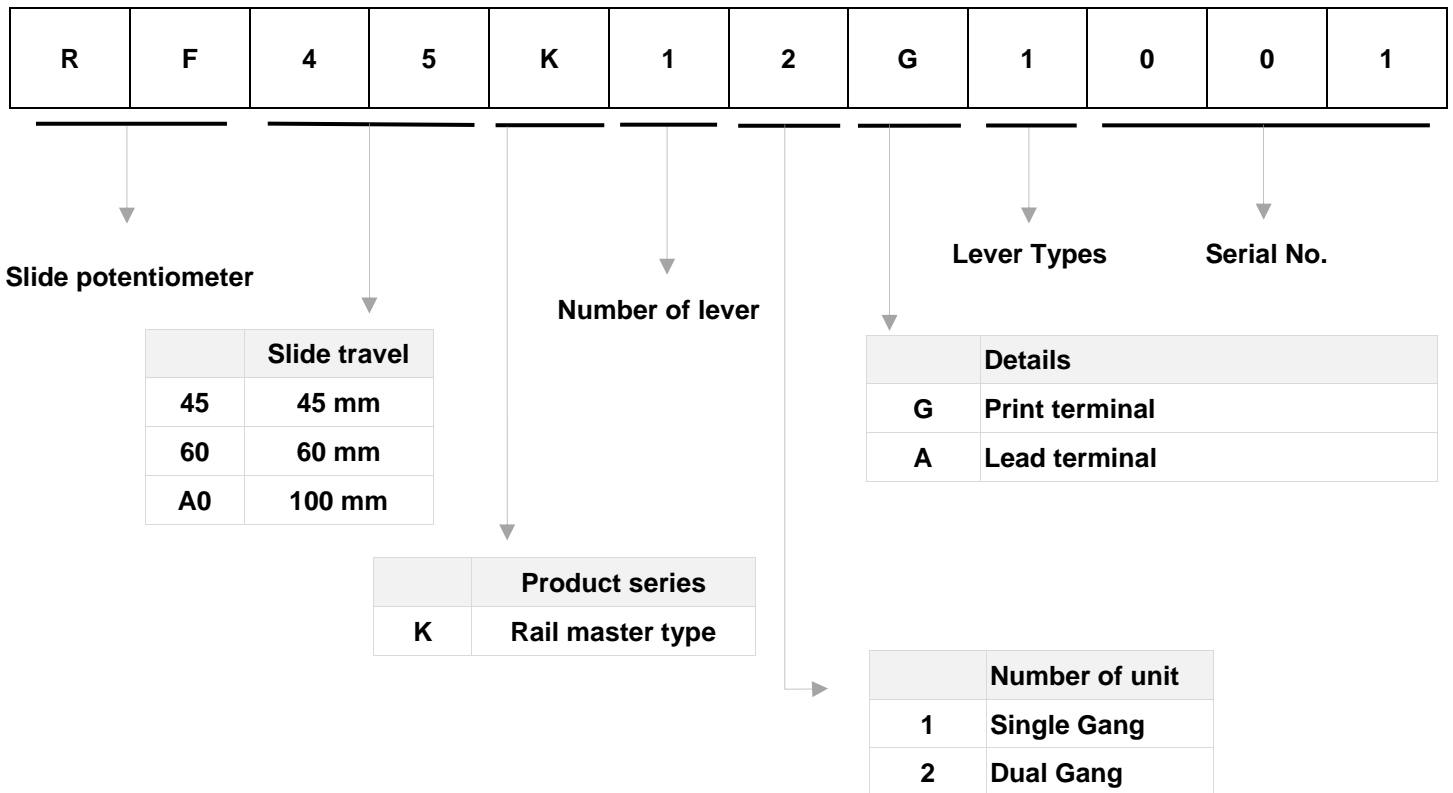

◆ COMMON SPECIFICATIONS

Characteristics	Specification
Operating temperature range	-10°C to +70°C
Operating force	60 gf MAX
Total resistance (KΩ)	5、10、20、50、100、250、500
Total resistance tolerance	±20%
Resistance taper	A,B,C
Sliding service life	100,000 cycles

SLIDE POTENTIOMETER

Rail Master Type

◆ LEVER TYPES

Unit : mm

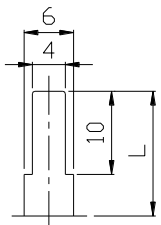
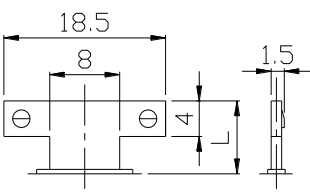
Material	Metal lever	
Lever type	3	9
Dimensions	$t=1.2$ 	$t=1.2$ 
Length (L)	15	20
		8.2

DIMENSIONS

Unit : mm

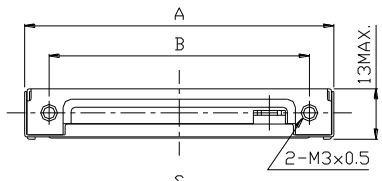
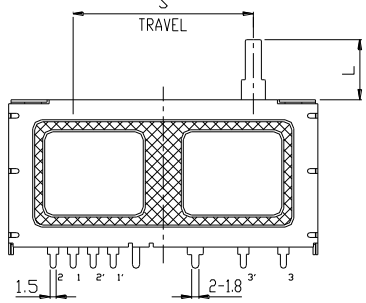
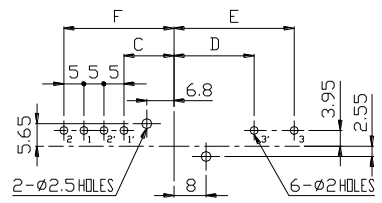
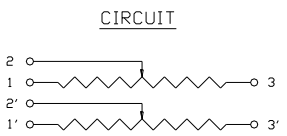
Model	Dimensions
RF□□K	    

P.C.B Mounting hole detail

Model	Dimensions	S	A (S+32.5)	B (S+20)	C	D	E	F
RF45K		45	77.5	65	12.5	20	30	27.5
RF60K		60	92.5	80	20	27.5	37.5	35
RFA0K		100	132.5	120	40	47.5	37.5	55