

SLIDE SWITCH

SSSU SERIES



◆ FEATURE

- Medium-sized slide switch of metal-frame type.
- 3mm travel.
- 8.5mm in lever height from P.C.B
- Horizontal knob type with cover available-direct knob setting possible.

◆ APPLICATIONS

- Switching of signals in VCRs, TV sets, radio cassette recorders, stereos, measuring instruments, vending machines, musical instrument, office machines, etc.

◆ COMMON SPECIFICATIONS

Items	Stand specification
Ratings	0.1A 30V DC (Resistive load)
Operating life without load	10,000 cycles
Initial contact resistance	25 mΩ max

◆ PRODUCTS LINE

Vertical

Poles	Position	Lever length	Frame		With cover	Without cover	Products No.	Drawing No.
			Printed	Snap-in				
1	2	6,9,12	•	•	•	•	•	SSSU012N
2	2	6,9,12	•	•	•	•	•	SSSU022N

Horizontal

Poles	Position	Lever length	Frame		With cover	Without cover	Products No.	Drawing No.
			Printed	Snap-in				
1	2	6,9	•	•	•	•	•	SSSU112N
2	2	6,9	•	•	•	•	•	SSSU122N

◆ SLIED SWITCH PRODUCTS NUMBERING SYSTEM

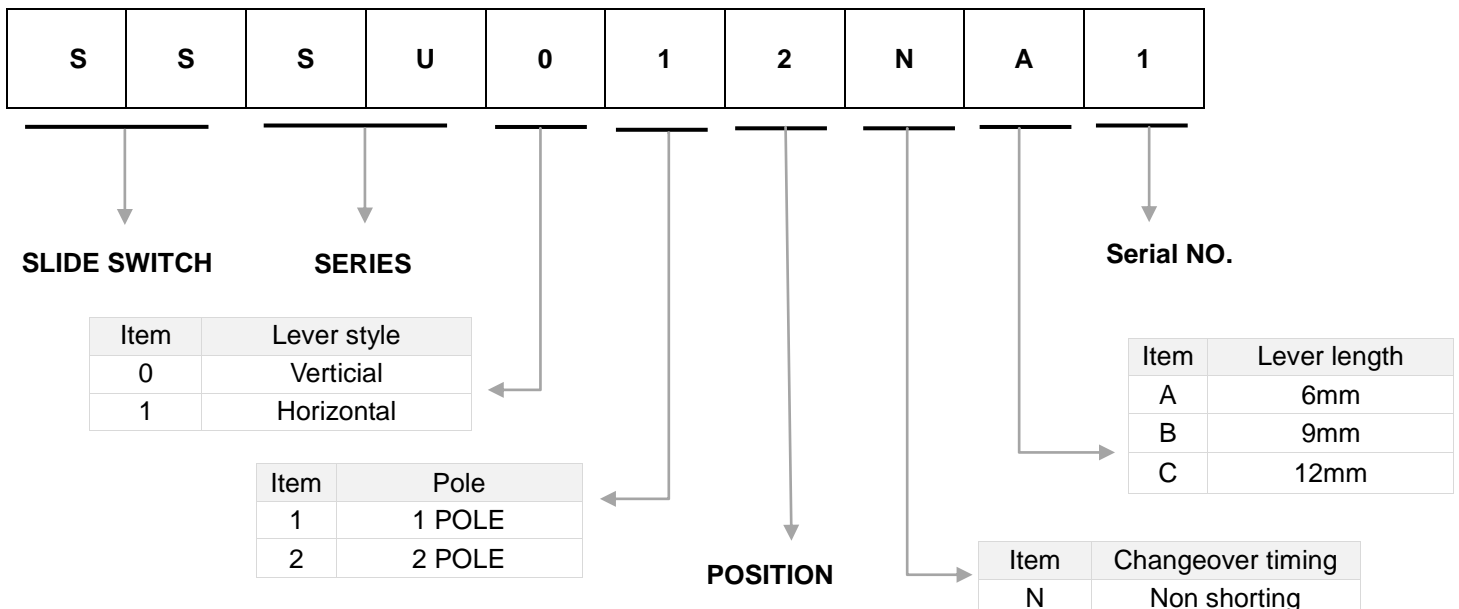

SLIDE SWITCH

SSSU SERIES

COMMON SPECIFICATION

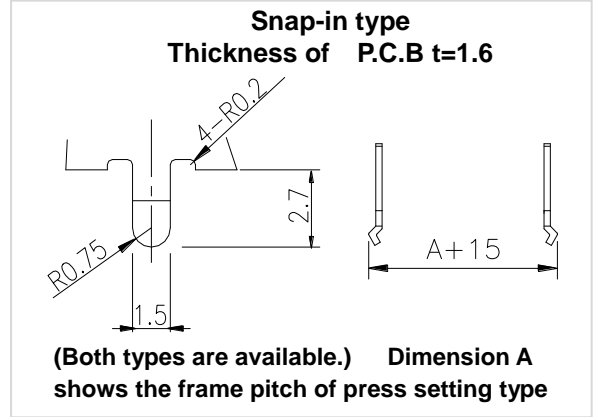
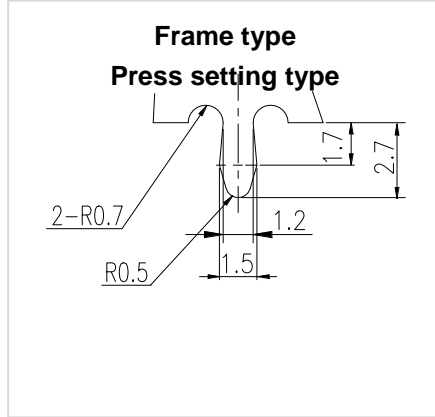
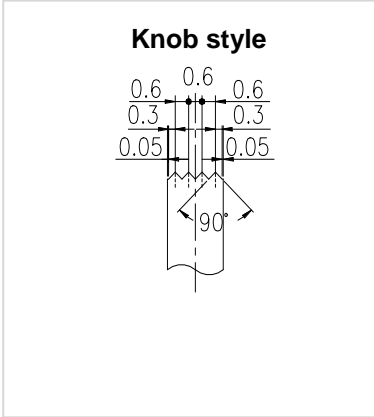

DIMENSION

Vertical knob type

Unit : mm

No	Pole-position	Dimensions	Circuit diagram (Viewed from the direction A) P.C. board mounting hole dimensions (Viewed from the direction a) (a) Press-in type (b) Snap-in type	
			(a)	(b)
1	1-2	<p>OPERATING FORCE WITH A CLICK: 200±100gf</p>		
2	2-2	<p>OPERATING FORCE WITH A CLICK: 200±100gf</p>		

SLIDE SWITCH

SSSU SERIES

◆ DIMENSION

Horizontal knob type

Unit : mm

No	Pole - position	Dimensions	Circuit diagram (Viewed from the direction A)	
			P.C. board mounting hole dimensions (Viewed from the direction a)	(a) Press-in type (b) Snap-in type
3	1-2	<p>OPERATING FORCE WITH A CLICK: 200±100gf</p>		
4	2-2	<p>OPERATING FORCE WITH A CLICK: 200±100gf</p>		

◆ Cover type

Unit : mm

Vertical cover	Horizontal cover
<p>T=0.3mm</p>	<p>T=0.3mm</p>